

Magnum Rack

Systèmes

CableTalk
Systems Inc.

Product Features

Finish

- Durable black textured powder paint finish

Structure

- Frame constructed of rugged 11 GA (0.120") steel
- Knock-down construction bolts together for ease of handling and assembly. Comes standard with 19" EIA standard 12-24 tapped mounting holes with permanently marked U-spacing identification
- All racks come standard tapped double-sided
- 1/4" Sturdy steel base with anchor holes for mounting to floor
- Rack is standard with 1 copper 12-24x1"L ground stud
- Extra-wide body with built-in cable management

Options

- Mounts rack shelves and cable management systems, as well as 19" EIA standard hardware
- Magnum horizontal cable manager available
- Magnum vertical cable manager available
- Magnum vertical cable manager for ganging multiple racks available
- Magnum overhead tray cable manager available
- Vertical tie plates with lances available for cable tie down
- Base dust cover available

Standard Dimensions

Knock-down Racks

Part No.	Style	Mounting Width (EIA)	Overall Height (Inches)	Usable Space (Inches)
CTM-1977-B	Double sided 12/24	19	84	77
CTM-1984-B	Double sided 12/24	19	90	84

Magnum Accessories

Part No.	Description	Width (Inches)	Depth (Inches)	Height (Inches)
CTH-CMS-2MAG-B	Horizontal cable manager	19	3.5	5
CTM-CMS-20-B	Vertical cable manager for 1977	4	84	4
CTM-CMS-21-B	Ganging Vertical cable manager for 1977	8	84	4
CTM-1977-TIE-B	Vertical Tie Plate with Lances for 1977	5.5	84	-
CTM-CMS-22-B	Vertical cable manager for 1984	4	90	4
CTM-CMS-23-B	Ganging Vertical cable manager for 1984	8	90	4
CTM-1984-TIE-B	Vertical Tie Plate with Lances for 1984	5.5	90	-
CTM-CMT-27-B	Overhead tray cable manager	27	1	14.5
CTM-19BDC-B	Base Dust Cover	26.5	6.25	1.5

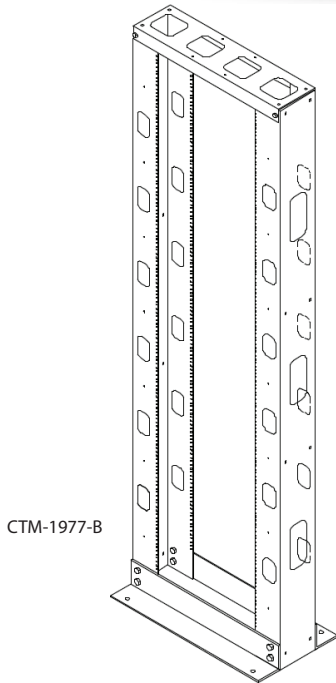

CTM-1977-B

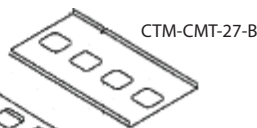

CTM-CMT-27-B



CTM-CMS-22-B

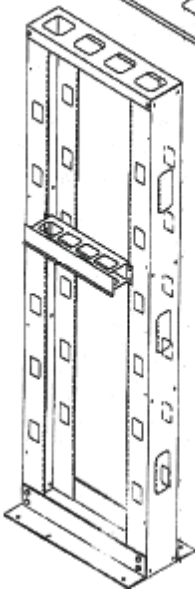

CTM-1984-B
Shown with
CTH-CMS-2MAG-B



CTM-CMS-23-B